



Tertiary Entrance Examination, 2002

Question/Answer Booklet

PHYSICS

Please place your student identification label in this box

Student Number: In figures

--	--	--	--	--	--	--	--

In words

Time allowed for this paper

Reading time before commencing work: Ten minutes

Working time for paper: Three hours

Materials required/recommended for this paper

To be provided by the supervisor

This Question/Answer Booklet

Physics: Formulae and Constants Sheet (inside front cover of this Question/Answer Booklet)

To be provided by the candidate

Standard items: Pens, pencils, eraser or correction fluid, ruler

Special items: MATHOMAT and/or Mathaid, drawing compass, protractor, set square and calculators satisfying the conditions set by the Curriculum Council for this subject.

Important note to candidates

No other items may be taken into the examination room. It is **your** responsibility to ensure that you do not have any unauthorised notes or other items of a non-personal nature in the examination room. If you have any unauthorised material with you, hand it to the supervisor **before** reading any further.

Structure of this paper

Section	No. of questions	No. of questions to be attempted	No. of marks out of 200	Proportion of examination total
A Short Answers	15	All	60	30%
B Problem Solving	7	7*	100	50%
C Comprehension and Interpretation	1 passage	All	40	20%

* Note that in Section B there is internal choice in one question. For this question only one alternative should be answered. Markers will be instructed to mark only the first attempt among the alternatives (unless clearly cancelled).

Instructions to candidates

1. The rules for the conduct of Tertiary Entrance Examinations are detailed in the booklet *TEE Handbook*. Sitting this examination implies that you agree to abide by these rules.
2. Write your answers in the spaces provided in this Question/Answer Booklet.
3. You may remove the enclosed *Physics: Formulae and Constants Sheet* from the booklet and use as required. This sheet is not to be handed in at the end of the examination.
4. Your answers to questions involving calculations should be evaluated and given in decimal form. It is suggested that you quote all answers to three significant figures, with the exception of questions for which estimates are required. Despite an incorrect final result, you may obtain marks for method and working, provided these are clearly and legibly set out.
5. Questions containing the specific instruction “**show working**” should be answered with a complete, logical, clear sequence of reasoning showing how your final answer was arrived at. Correct answers which do not show working will not be awarded full marks.
6. Questions containing the instruction “**estimate**” may give insufficient numerical data for their solution. You should provide appropriate figures to enable an approximate solution to be obtained.
7. When descriptive answers are required, you should display your understanding of the context of a question. An answer which does not display an understanding of Physics principles will not attract marks.

SECTION A: Short Answers**(60 marks)**

Attempt **ALL** 15 questions in this section. Each question is worth 4 marks. Answers are to be written in the spaces provided.

1. A transformer has 200 turns in the primary coil. An AC signal of 120 V is applied. If the output coil has 600 turns what is the secondary voltage?

2. A wire carrying an electric current is placed between the poles of a horseshoe magnet. The current is going into the page.

Show on the diagram the direction of the force on the wire.

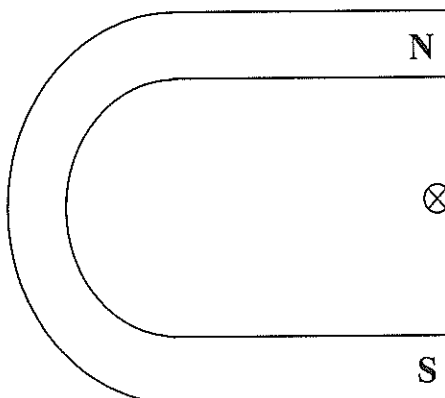
**SEE NEXT PAGE**

3. Two children sit on opposite ends of a see-saw. Estimate the torque exerted by one of the children about the pivot point of the see-saw.

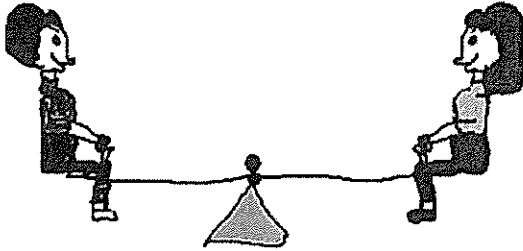

Figure 1
Example of a see-saw

4. When an electron moves from one energy level to another in a particular atom, a photon of infra-red radiation is produced. Estimate the difference in energy between these two levels. Give your answer in electron volts.

5. Consider the following two graphs of displacement due to wave motion. Notice that the horizontal co-ordinates are not the same.

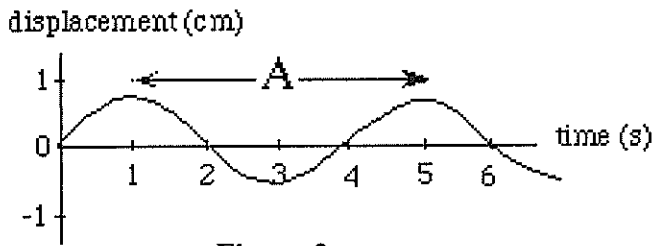

Figure 2a

Figure 2
Graphs of displacement for two waves

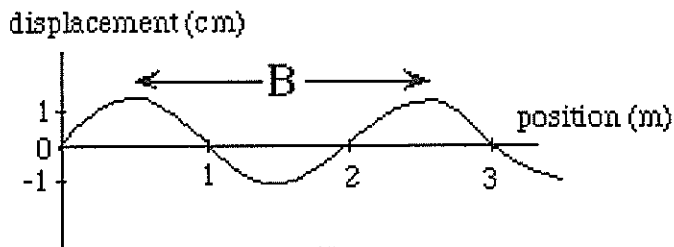

Figure 2b

- a) What does the quantity A in Figure 2a represent?

- b) What does the quantity B in Figure 2b represent?

- c) If both waves have the same frequency, estimate the wave speed.

6. Two metal rings R and S are placed in a uniform magnetic field. R is continuous and S has a gap, but otherwise they are identical. The plane of each ring is perpendicular to the field lines.

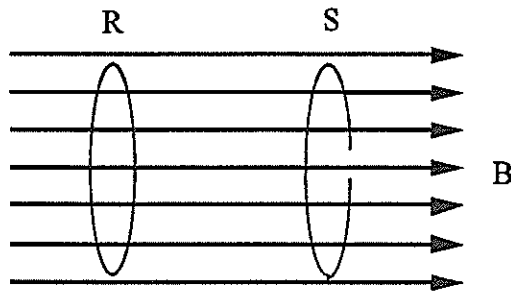

The magnetic field is decreased at a constant rate. Which ONE of the following statements is true?

- [A] No emf is induced in the split ring S.
- [B] An emf is induced in both rings.
- [C] Equal heating occurs in both rings.
- [D] Heating does not occur in either ring.
- [E] There is a torque on both rings.

Write your choice in the box.

State the main reason why you think your choice is correct.

7. The light emitted from a source can be a line emission spectrum, a band spectrum or a continuous spectrum. Which of these is emitted by the filament of a light globe? Give the main reason for your selection.

8. A modern piano consists of strings of various lengths which are made to vibrate by hammers which hit the strings when the appropriate key is pressed. In general, when a string is hit it will vibrate at its fundamental frequency f_0 as well as higher harmonics nf_0 , ($n = 2, 3, 4, \dots$).

In order to suppress the 'unmusical' seventh harmonic ($n = 7$), the piano is designed so that the hammers hit at a point where the seventh harmonic would normally have a node. For a string of length 1.00 m, where on the string should the hammer hit?

9. What are the dual properties of light? For each of these two properties, give an example where it is exhibited by light.

The following information relates to questions 10, 11 and 12.

Jupiter, the largest planet in the solar system, has a mass more than 300 times that of Earth. Two of Jupiter's moons are Io and Ganymede. The masses, radii and orbital radii of these moons are given in the table.

	Io	Ganymede
Mass (kg)	8.93×10^{22}	1.48×10^{23}
Radius (m)	1.81×10^6	2.63×10^6
Orbital radius (m)	4.22×10^8	1.07×10^9

10. What is the acceleration due to gravity on the surface of Ganymede?

11. What is the minimum possible gravitational force exerted on Ganymede by Io?

12. Estimate the orbital period of Io around Jupiter. Give your answer in hours.

13. A free body diagram shows all the forces acting on a body. Draw the free body diagram for a block sliding along the floor some time after it has been kicked and while it is still moving. Show on your diagram the direction of motion of the block.

14. A charge is *moving* through the vacuum of deep space. The magnetic field in the region surrounding the charge is zero.

Is this statement true or false? Give a reason for your answer.

15. Sketch, on the axes provided below, the stress-strain curves you would expect from (i) a length of bone and (ii) a piece of rubber. Label the axes clearly.



SECTION B: Problem Solving**(100 marks)**

Attempt ALL 7 questions in this section

Note that some questions have alternatives. Follow the directions in these questions with care.

1. [Total 13 marks]

Cyclotrons are used to accelerate charged particles to high speeds. In a cyclotron, charged particles are placed in a magnetic field so that they travel in a circle. For a particular cyclotron, the magnetic field is 0.35 T and protons of kinetic energy 0.23 MeV are being produced.

a) [4 marks]

i) Calculate the radius of the circle travelled by the protons.

ii) What would happen to the radius of the circle if the proton energy were increased? Give the reason for your answer.

SEE NEXT PAGE

b)

[4 marks]

i) The protons hit a target. If all the energy of one proton is converted into a single photon of electromagnetic radiation, calculate the wavelength of the radiation.

ii) In what region of the electromagnetic spectrum is this radiation?

c) Answer ONE of the parts i), ii) and iii) in the space below.

[5 marks]

i) *Context : Sunlight and starlight*

The atmosphere acts as a shield against radiation. Explain how it acts as a shield. Explain clearly the physical process involved.

ii) *Context : Medical Applications*

Gamma rays are used in cancer therapy. Why are gamma rays used? How do they affect human tissue? Explain clearly the physical process involved.

iii) *Context : Domestic / Industrial Applications*

X-Rays are used to inspect welds for cracks. Why are X-rays used? How do they show up cracks? Explain clearly the physical process involved.

SEE NEXT PAGE

2. [Total 18 marks]

The type of sound made by a certain Australian parrot is a “squawk”. A parrot produces a squawk with an intensity of 100 W m^{-2} at a distance of 1.0 m from its beak.

a) [4 marks]

What is the intensity in decibels of the parrot’s squawk compared to the hearing threshold for humans at a distance of 1.0 m?

b) [6 marks]

At what distance from the parrot will the sound level be comparable to quiet conversation levels of 60 dB? You can assume the inverse square law holds, so that the intensity is inversely proportional to the distance squared.

c)

[3 marks]

At the distance where the sound level from one parrot is 60 dB, what would the sound level be if a flock of 6 parrots all squawked at once?

d)

[5 marks]

You notice that when the parrot squawks, a bell in its cage rings. Describe clearly the process that causes the bell to ring. Why does the bell ring at a particular frequency?

3. [Total 14 marks]

Poles that support electricity wires often have a cable running at an angle down to a support buried in the ground. The purpose of these cables is to stop the electricity wires from pulling the poles over. The diagram below shows one such pole.

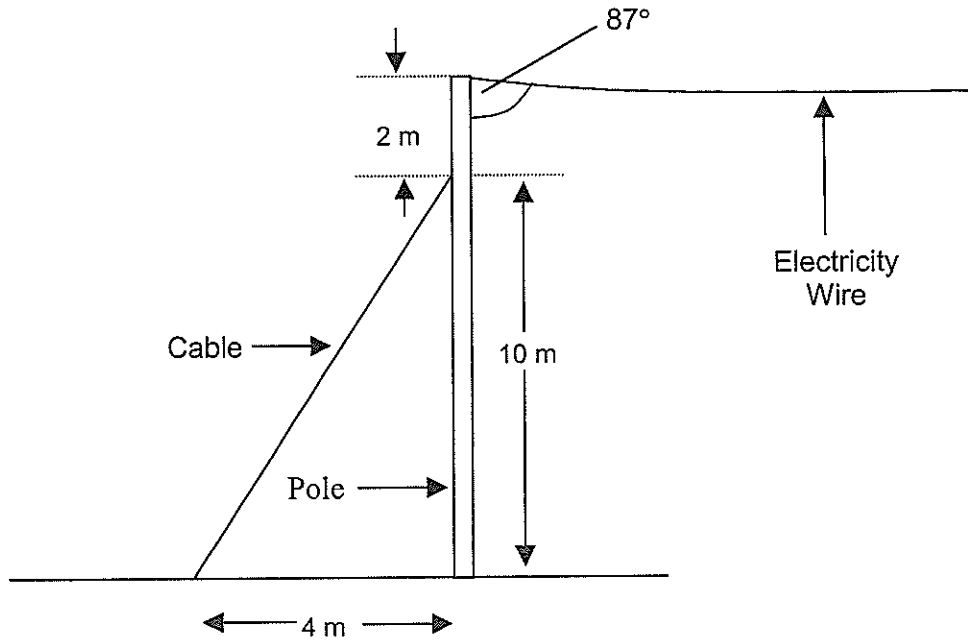

a)

[4 marks]

With the aid of a diagram, explain how the cable helps prevent the pole being pulled over by the electricity wire.

SEE NEXT PAGE

b)

[6 marks]

Suppose that the force exerted by the electricity wires on the pole shown in the diagram is 1500 N. Calculate the tension in the support cable so that the pole is not moved in any direction. Assume the wires make an angle of 87° with the pole.

c)

[4 marks]

The tension in the supporting cable has a downward component so it will act to shorten the pole slightly. Estimate how much shorter a typical wooden pole would be as result of this tension. Show your working clearly. (Young's modulus for wood is approximately 10% of the value for brass.)

4. [Total 20 marks]

A moulded copper device has the shape of a rod of diameter 6.8 mm and length 160 mm with two balls, each of mass 180 g, at its ends. A vertical shaft is joined to the centre of the rod. When this device is spun about the axis of the shaft fast enough, the rod fractures.

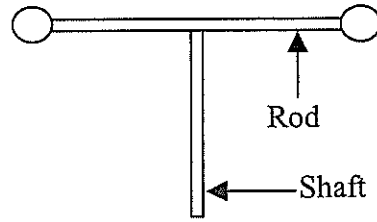

a) [4 marks]

Explain why the rod fractures.

b) [6 marks]

Ignoring the mass of the rod, calculate the maximum rate at which this device can be spun without the rod fracturing. (Give your answer in rotations per second.)

- c) [6 marks]
- i) Show on the diagram of the device its centre of mass. Ignore the mass of the shaft.
 - ii) If there were only one ball, the device would vibrate violently when the rod was spun. Why is this? Use a diagram in your explanation.

- d) [4 marks]
- If the balls were attached to the shaft by strings instead of the rod, the balls would rise higher as the shaft was rotated faster. With the aid of a diagram, explain why.

5. [Total 8 marks]

a)

[4 marks]

A device consists of two bar magnets attached to a rigid aluminium rod (see diagram below). Each magnet is 50 mm long. The magnets are placed with closest ends 50 mm apart. The two magnets are the same distance from the centre of the aluminium rod. Sketch on the diagram the magnetic field due to the magnets. Use arrows to indicate the field direction.

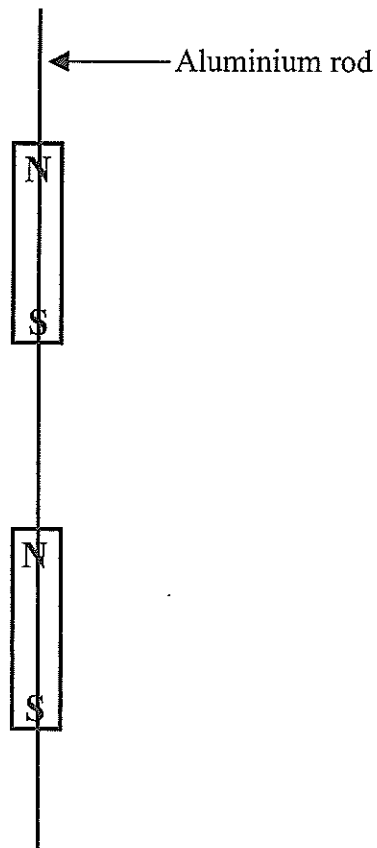

SEE NEXT PAGE

b)

[4 marks]

The device is now held one metre above a single coil of wire with a diameter of 200 mm as in the diagram. Any current flowing through the loop is monitored with a galvanometer labelled G in the diagram. Its output is positive for a clockwise current as viewed from above, and negative for an anti-clockwise current.

When the device is dropped through the loop, a current passes through the meter. Four possible graphs of current versus time are shown in the diagrams A, B, C and D (below).

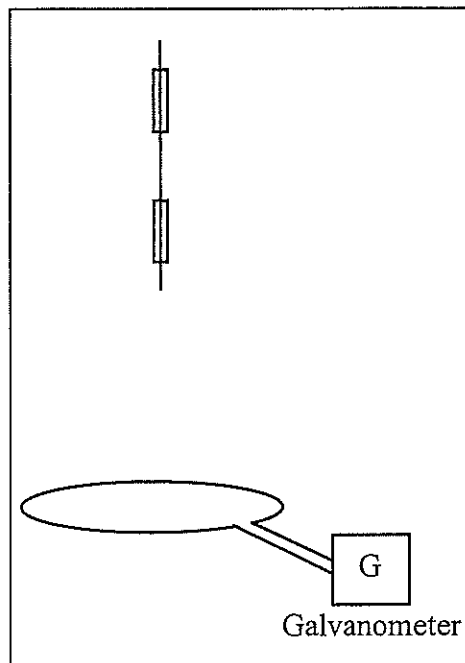

- i) Select the graph which you think best represents the one you would expect to observe.
- ii) Indicate on the graph at which point the device is mid-way through the loop.
- iii) Explain why you chose this graph.

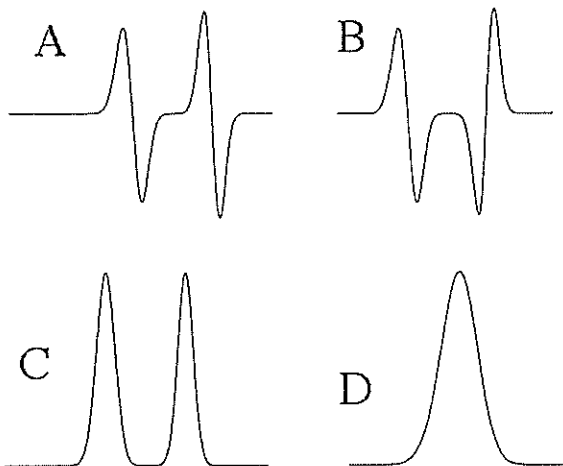

6. [Total 15 marks]

Imagine you are to plan the following stunt.

A motor bike is to be ridden up a ramp and land on the edge of the horizontal roof of a two storey building. The height of the building is 12 m. The top of the ramp is 20 m from the building and 3.2 m above the ground. The final slope of the ramp is 50° above the horizontal.

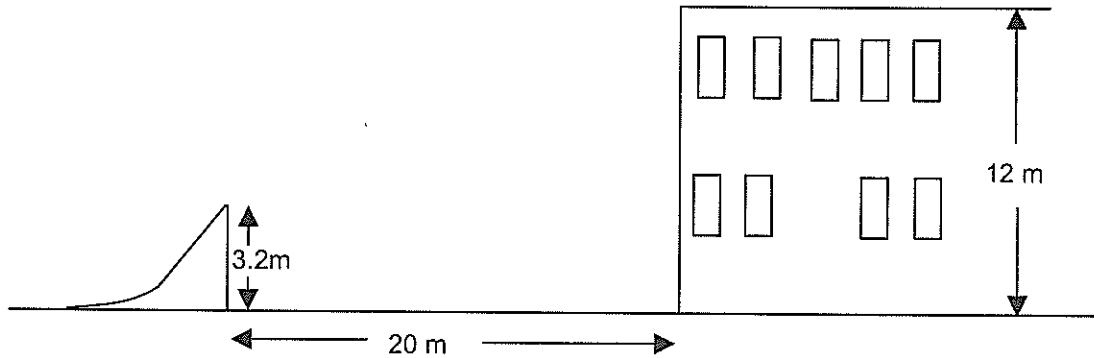

In the calculations to follow, assume that air resistance is negligible and that the motor bike and rider are a point mass.

- a) [9 marks]
- i) Write an equation showing the relationship between the horizontal position of the motor bike and the time elapsed since leaving the top of the ramp. State clearly what your variables represent.

- ii) Write an equation showing clearly the relationship between the vertical position of the motor bike and the time elapsed since leaving the top of the ramp. State clearly what your variables represent.

- iii) Use your equations from parts i) and ii) to find the minimum speed at which the motor bike should leave the top of the ramp in order to land on the top of the building. Show clearly your working.

- iv) Do you think this speed can be achieved in this situation? Justify your answer.

b)

[6 marks]

Give an example from the context you have studied where air resistance has an appreciable effect on the motion of a projectile. For your example,

- show how the path of the projectile is affected by air resistance.
- draw a diagram showing all the forces exerted on the projectile at the top of its path and at one other point.
- state two factors which would cause an increase in air resistance.

7. [Total 12 marks]

A bicycle has an electric generator attached to the rear wheel to provide power for a headlamp. The barrel of the generator rubs against the bicycle wheel, which causes it to rotate. Inside the generator there are 400 turns of wire forming a coil with an average area of 140 mm^2 . The coil rotates between the poles of a permanent magnet.

When the bicycle is ridden at 1.5 m s^{-1} the generator is rotating at 83.3 revolutions per second and generates a voltage of 4.4 V AC across the lamp, whose resistance is 1.1Ω .

a) [4 marks]

i) What is the frequency of the AC voltage generated?

ii) What power is provided to the lamp?

b) [4 marks]

Calculate the approximate magnetic field strength passing through the coil.

c)

[4 marks]

With the aid of a diagram, explain how a commutator could be used to change the output of the generator from AC to DC.

SECTION C: Comprehension and Interpretation**(40 Marks)**

This section consists of **ONE** passage followed by questions. Every question should be attempted.

Read the passage carefully and answer all questions at the end of the passage. Candidates are reminded of the need for clear and concise presentation of answers. Diagrams (sketches), equations and/or numerical results should be included as appropriate.

THE ACOUSTIC SOUNDER*Paragraph 1*

Atmospheric pollution is a topic of common concern. Perth has experienced an increasing amount of pollution in recent years. One of the important factors which determines how bad the pollution will be is the presence of atmospheric inversions.

Paragraph 2

Up to altitudes of several thousand metres, the air temperature normally falls as you rise higher in the atmosphere. Under certain circumstances, the temperature rises as you go higher, up to a certain height, above which the temperature falls in the usual manner. The layer in the atmosphere where this reversal of the temperature gradient occurs is called an inversion. The importance of inversions is that when they occur pollution is trapped below them.

Paragraph 3

The height of these inversions can be measured by a device called an acoustic sounder. It does this by broadcasting a short pulse of sound upwards into the atmosphere. A portion of the pulse is reflected from the inversion, and the reflected pulse is picked up by the sounder. The time between the emitted pulse and the reflected pulse is then used to find the height of the inversion. The principle of this device is illustrated in Figure 3.

Paragraph 4

A typical acoustic sounder consists of an array of loudspeakers spread out in an approximately circular shape about 2.5 metres in diameter (see Figure 4). The array is horizontal so the sound travels directly upwards. All the loudspeakers are connected in phase. When operated in this way, the loudspeakers act as if they were a single loudspeaker cone of the same diameter as the array. A short pulse of frequency 1650 Hz is fed to the loudspeakers to create a sound pulse.

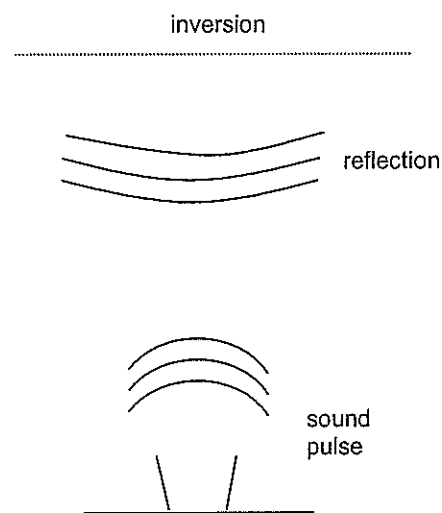

Figure 3
Principle of the acoustic sounder

Paragraph 5

The diameter of the array is made as large as possible, since then the sound spreads out less. In fact, the angular width (θ) of the emitted sound beam, in degrees, is given approximately by

$$\theta = 140 \frac{\lambda}{a}$$

where λ is the wavelength of the sound and a is the aperture (diameter) of the array.

Paragraph 6

The speed of sound has to be known in order to calculate the height of the inversion. It is known that the speed of sound in any medium depends on just two properties of the medium, its density ρ and a constant called the bulk modulus B . The speed of sound (v) is then given by

$$v = \sqrt{\frac{B}{\rho}}$$

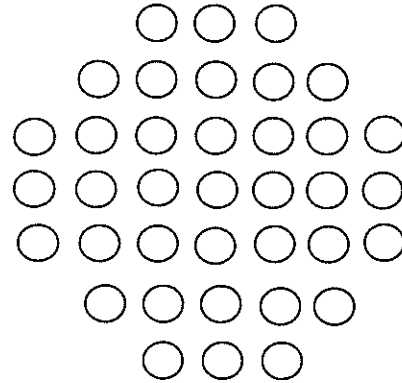

Figure 4
A loudspeaker array, looking from above

The density of air depends on its pressure, so this expression can be modified to give the sound velocity in terms of the air pressure P . Under typical conditions, this comes out to be

$$v = \sqrt{\frac{8.45 \times 10^4 B}{P}}$$

where P is in Pascals.

Paragraph 7

The sounder emits pulses a few seconds apart, and the time taken for the reflections to return to the ground is plotted against the time of day. A simplified form of this plot is shown in Figure 5. From this, the height of the inversion can be calculated.

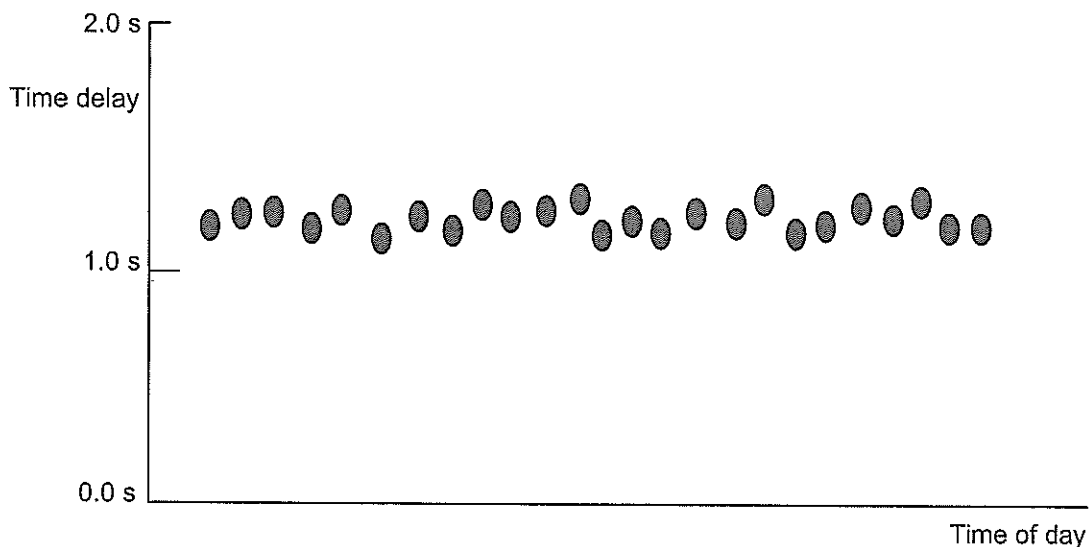

Figure 5: Record of echoes received by an acoustic sounder in Perth.

Each reflection is shown by a "blob", and the distance above the horizontal axis shows the time between the pulse and its reflection. The horizontal distance shows a period of ten minutes during the day.

a)

[8 marks]

i) Estimate the average height of the inversion.

ii) Estimate how long it would take a pulse of sound to return to the ground after being reflected from an inversion 450 m above the ground.

iii) Will the velocity of sound at higher altitudes be greater, the same as, or less than, its velocity on the ground? Explain your choice.

b)

[4 marks]

If the initial intensity level of the sound was 140 dB and the intensity level of the reflection is 55 dB, calculate the intensity of the reflected sound as a fraction of the initial intensity.

c)

[6 marks]

i) What are the units of the bulk modulus B ?

ii) Estimate the bulk modulus of air.

SEE NEXT PAGE

d)

[7 marks]

Bridgette has carried out an experiment to determine the bulk modulus of air under typical conditions by measuring the speed of sound in air. A plot of her results is shown in Figure 6.

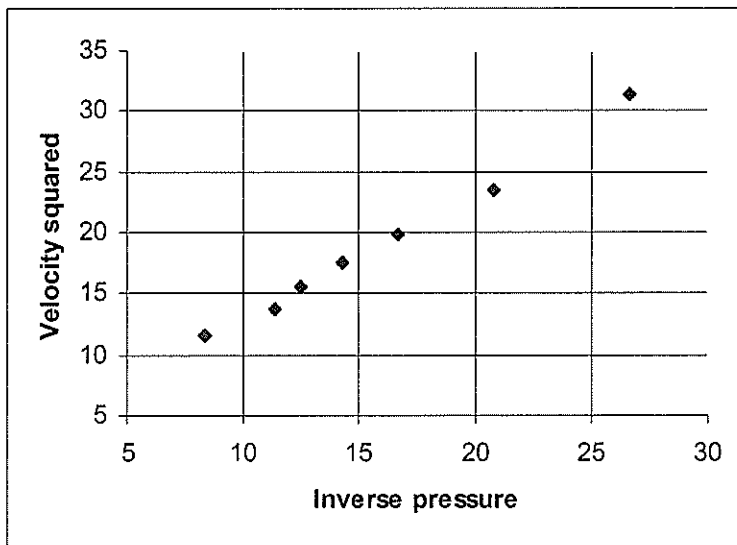

Figure 6: Plot of v^2 vs $1/p$.

The figures on the axes have been multiplied by scaling factors. The highest value on the x-axis represents $30 \times 10^{-6} \text{ Pa}^{-1}$ and the highest value on the y-axis $35 \times 10^4 \text{ m}^2 \text{ s}^{-2}$.

- i) Draw a line of best fit.
- ii) Determine the slope (gradient) of the line of best fit.

- iii) Using the slope you have found, calculate the bulk modulus of air.

e)

[6 marks]

i) Name the principle which causes the sound pulse to spread out (paragraph 5) rather than go up as a parallel beam.

ii) What would happen to the angular spread of the sound beam if the diameter of the array were increased? Give a reason for your answer.

iii) How wide will the ascending beam be at a height of 350 m?

f)

[6 marks]

i) State one possible major source of the uncertainty in the measurement of the inversion height (see Figure 5). Explain why the uncertainty arises.

ii) Estimate the magnitude of the uncertainty caused by the source you have described.

g)

[3 marks]

The speed of sound in steel is much greater than the speed of sound in air. Why do you think this is?

A blank sheet of lined paper with horizontal ruling lines. The lines are evenly spaced and run across the width of the page. There are three binder holes punched along the left edge. The page is otherwise empty.

(

(

(

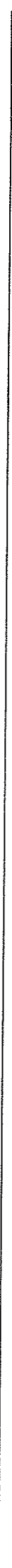

ACKNOWLEDGEMENTS

SECTION A

Question 3: [Diagram]. (n.d.). Retrieved July 27, 2002, from
<http://www.dade.k12.fl.us/wachapman/graphics/seesaw/gif>

SECTION C

Information and data from Curtin University of Technology, Department of Applied Physics.
(n.d.). *Report PD130/1977/ES5*. Bentley, WA: Author.